

## SAVING VOSKOPOJA, COMPLETE PHOTOGRAMMETRIC COVERAGE OF THREE ALBANIAN PAINTED CHURCHES

T. Leroy

Art Graphique et Patrimoine, 15 avenue J. Jaurès, F-94340 Joinville le Pont, France

Email: t.leroy@artgp.fr

**KEY WORDS:** Church, Digital Photogrammetry, Image Unwrapping, Preservation, Rectification

### ABSTRACT

This paper gives an overview of the way to produce exhaustive multi-user documentation of an endangered site in Albania through photogrammetric applications. The complexity of the structures to be documented has led us to use a large range of available photogrammetric and survey techniques. The development of low-cost photogrammetric material: software, cameras, personal computers, offers the possibility to achieve quickly the survey and restitution of complex architectures and frescoes. Though methods to document frescoes are already well described in the literature, we have to spread their use by convincing the users of their utility, and to find ways to produce unwrapped documents even more quickly and accurately as the classical photogrammetric documentation.

### 1. INTRODUCTION

Voskopoja (south Albania), located 35 km from the Greek border, was a renowned orthodox pilgrimage centre in the XVIIIth century. All that remains of this prestigious past are six churches and a monastery. Well preserved externally, the interiors are completely covered with frescoes. Unfortunately, the frescoes have been badly damaged by water infiltration and continue to deteriorate.

The French non-government association Patrimoine sans Frontières (or "PSF") discovered the slow deterioration of the treasures of Voskopoja around 2002. Following the creation of a scientific committee, comprising members of PSF, the ENP (Ecole Nationale du Patrimoine, Paris), architects, and the IMK (Albanian Culture Ministry), the initial step was to comprehensively and precisely document the interiors and exteriors of the three most endangered churches, which would underlie all future works and restorations.

In Voskopoja, only scarce paper documentation existed. Architects, restorators, art historian were in need of documents to report their analysis, plan their future works (scaffolding implantation, frescoes restoration...), and compare the churches with others in Albania, Greece and Macedonia.

Architects needed 2D CAD drawings showing the main volumes, indeed as the churches are quite internally completely covered with frescoes (90%), it is very difficult to estimate and understand the spatial internal organisation.

Restorators needed a complete documentation of frescoes only in an easily understandable way. The external aspect of the churches is simple but, in the inside, the game of arches, and domes makes the comprehension impossible without enlightening documents such as rectified and unwrapped images.

It has been decided to produce a documentation that could satisfy all the users and constitute an exhaustive geometric database to conduct works. This complete record is a geometric and radiometric memory that virtually stops the damages' extent.

For each church the following documents had so to be draw:

1. CAD drawings at scale 1/50: inside/outside horizontal section, multiple longitudinal and transversal sections in a manner to see each wall, exterior elevations.
2. Rectified images at scale 1/20: any surface had to be documented as an unwrapped image or an orthophoto. This includes walls, ground, arches and domes.

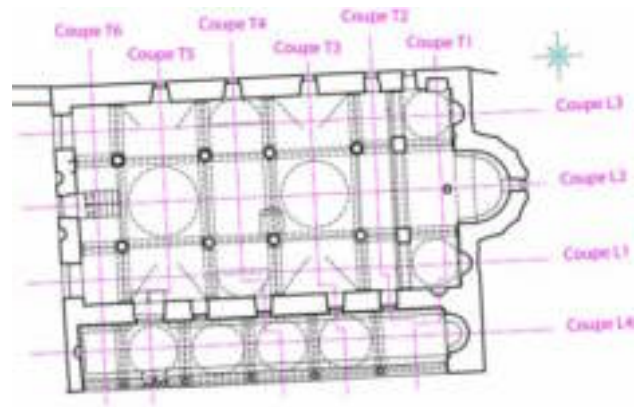

Figure 1. Saint Athanase, sections and elevations situation.

The survey and evaluation mission took place during the summer of 2003, with members of the scientific committee and Art Graphique.

### 2. DATA ACQUISITION

As the list and type of documents to establish was set, it became thus possible to define the way to do it properly in time. Other facts came moreover into account: the way from France to Albania and Voskopoja is not an easy one especially for sensitive material. Once at the airport in Tirana, 6 hours of car are requested to join the spot.

A rugged, well known and robust material has been chosen to avoid any breakdown: a reflectorless tacheometer, a reflex camera Fuji S2 Pro (2014\*3010 CCD sensor) with pre-calibrated short focals (15mm, 24mm, 30 mm) and a set of powerful flash lamps.

A power generator was bought in Korçe to ensure local lightning and alimentation of portable computers. Three or four days were allowed for each church because a strict survey planning had been scheduled in France.

#### 2.1 Photographs

For the photographs, some tables (see below) helped to evaluate the maximum distances to the object according to the focal length, to guaranty an optimal radiometric record.

Focal length	Maximum distance to the object	Terrain maximum image size
15 mm	3.3 m	5.1 m * 3.4 m
24 mm	5.3 m	
30 mm	6.6 m	

Table 1. Shot parameters according to the focal length, calculated at scale 1/20 for a 300 dpi plot (physical optimal pixel size: 1.7 mm).

The goal was to avoid thinking too much during the acquisition; this phase had to be quite mechanical. Each part of the church was photographed from three points of view. The camera was connected to a portable computer and every shot quality was checked before to be recorded. Furthermore, precise zoning helped to classify the data for future uses (one cell is referred to by its situation on transversal and longitudinal section i.e.: T6L1 refers to the SW corner cell).

### 2.2 Survey

For the survey, a list of details to measure was available in order not to forget anything for each tacheometer station: natural control points for ground and walls, sections, plan etc. Polygonal measurement and survey were conducted at the same time to go faster. Round-trip distances and level differences were checked each evening and the polygonal least-square adjustment was performed on the last day as a final check to conclude a church survey.

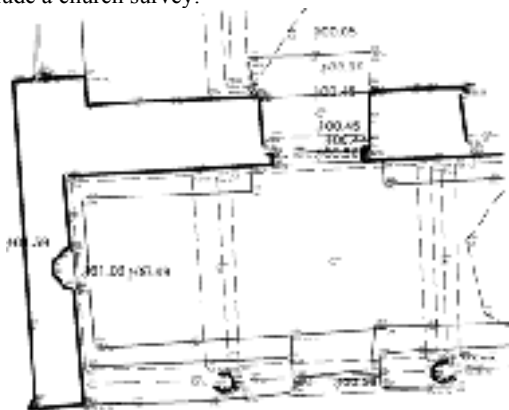

Figure 2. Raw data directly extracted from the coded survey system.

The horizontal and vertical sections were measured through a coded survey system connected to the tacheometer that helped doing quickly a more reliable work. It permits to avoid sketches and to directly do the interpretation while surveying, decreasing thus the office work (Figure 2). As we said upper, painted surfaces make the estimation of volume details very difficult on photographs. Measuring directly the sections with a reflectorless tacheometer permitted to skip a difficult and time consuming step in convergent photogrammetry.

By calculating the polygonal line on site at the end of the survey, we could check the survey completion and then manually measure the lacks.

This procedure, easy to implement, sure and quick, saves 80% time at the office.

## 3. PHOTOGRAMMETRIC WORKS

### 3.1 Photogrammetric adjustment

In view of the diversity of the final documents, the processing step was carefully scheduled not to lose time uselessly. However, fortunately not all the photographs needed to be adjusted. Actually camera positions were calculated only to determine some details (capitals, columns...) by convergent photogrammetry or to deal with the photographic representation of the ceilings.

As the number and reliability of the control points were high, no global adjustment was necessary. At least five control points were visible on each block so a locally adjusted image inserts itself perfectly in the object space.

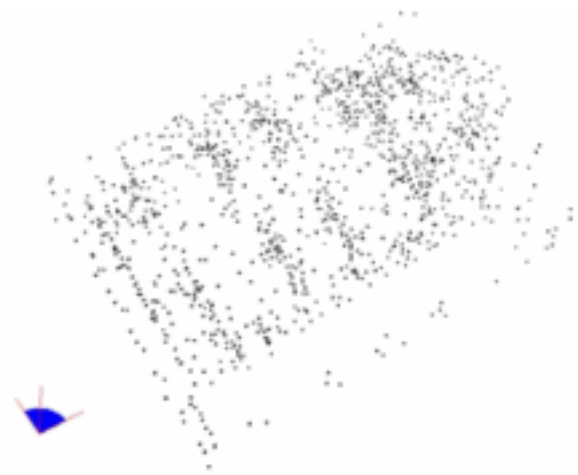

Figure 3. Inside and outside 3D control points.

The different focal lengths were calibrated in France but a control was conducted in Albania to check the camera stability in case of a shock during the transport; it revealed no significative change.

### 3.2 Flat surfaces

Flat surfaces or supposed so (i.e. walls and ground) were processed using projective rectification which parameters are set from the multiple control points. For this purpose the camera distortions, important with short focals are taken into account. However, we rapidly noticed that the frescoes' structure would be a serious problem. Indeed the frescoes are painted on a fresh plaster layer roughly spread on the masonry. It induces that not any surfaces is really flat. To minimize this volume effect that creates inaccuracies in the rectified images, photographs were taken the most orthogonally to the surface and with the longest focal possible.

The rectified images are directly connected to the average plane defined by the control points and can be then automatically mosaïcked via this link to the object space. The final touch up is performed under the Gimp software; it consists in adjusting the corresponding radiometries and the little geometric discontinuities mainly due to the imperfect flatness of the surfaces. A layer containing the control points helps to check the final accuracy evaluated to 2 cm.

### 3.3 Curved analytical surfaces

#### 3.3.1 Transverse arches and barrel arches

Cylindrical arches had to be unwrapped to be presented as flat images. Special procedure developed for castle towers and curved elevations, previously programmed, were used.

To produce an unwrapped image, some important parameters have to be set (Figure 4):

1. Cylinder parameters: a full 3D approach is used to spatially determine a cylinder; a fixed point  $P_0 (X_0, Y_0, Z_0)$ , three rotations using a topographical system ( $\alpha, \nu, \kappa$ ) to orient the y axis cylinder system (Kraus, 1996, p.16) and the radius. Some of these parameters have no influence (one of  $X_0, Y_0$  or  $Z_0$  can always be set to zero and  $\kappa$  is always set to zero) reducing them to five. These parameters are evaluated through a set of control points by an iterative surface fitting process using approached values.
2. Camera position: the camera position is essential, as multiple points of views were needed because of the beams, we chose a bundle block adjustment instead of a DLT.
3. Spatial interest zone to unwrap: four parameters (two angles:  $\alpha_d$  and  $\alpha_f$ , two distances to  $P_0$ :  $y_d$  and  $y_f$ ) define this area on the cylinder.
4. Final pixel size for the resampling (1.7 mm and bilinear interpolation).

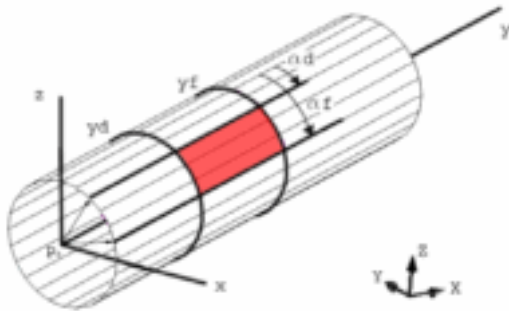

Figure 4. Cylinder unwrapping parameters ( $\alpha=-97\text{gr}$ ,  $\nu=4\text{gr}$ )

For each pixel of the unwrapped image, the corresponding XYZ position is found, and then by ray-tracing the 3D point into the original image, the ij position gives the RGB value (Karras, 1997).

Typically, several images are necessary to record the whole arch, the unwrapped images are mosaïcked then geometrically and radiometrically adapted. Of course, by using an analytical surface, this technique is dependant to the real shape of the cylinder. As we said upper, the frescoes' support is roughly flat and the damaged areas vary from the ideal shape. These areas, visible from different points of view create inaccuracies that are corrected in the mosaïcking step.

This procedure was applied successfully to the barrel arches. However, by studying the surface fitting results and the unwrapped images of the arches, we noticed that the results could be a lot better. Due to their deformations, the arches' section is not a circle but looks like a basket handle composed of several circles. We have changed the approach for the arches by working the CAD drawings where the exact arches' profile was visible (Figure 5).

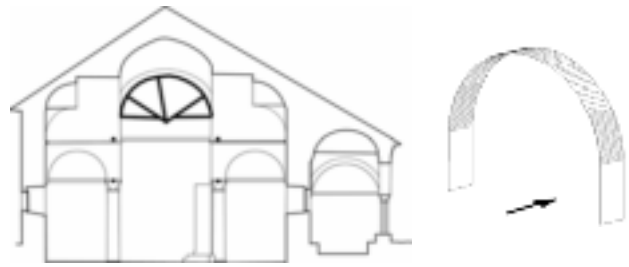

Figure 5. The transversal section T4 (view to the east) and the main transverse arch composed of four cylinders implemented as an extruded surface (result in Fig. 11).

An arch was considered as an extruded surface which profile was defined in the CAD drawings. Due to their small width (no more than 60cm) the direction of extrusion didn't need high accuracy and was set perpendicular to the section plan.

We thus developed a multi-cylinder unwrapping procedure; the user had just to select the profile and direction of extrusion (composed of polylines) in Autocad. A lisp macro automatically wrote a text file containing the cylinders' parameters. The program successively unwrapped the different parts of the original image and stucked them together.

The different 'multi-unwrapped' images are mosaïcked as precedently.

This way of unwrapping arches permits to eliminate a great part of the geometric discrepancies in the final images. It also permits to unwrap in one step more complex shapes composed of plans and several cylinders (plans are then considered as cylinder with quite infinite radius).

However this solution has to be handled with care when dealing with long extrusion distances.



Figure 6. A clover-unwrapping of a groined arch in the cell T5L3.

The unwrapped arches had also to be represented as orthophotos in the sections. A special program was created therefore to reduce the unwrapped images to orthophotos according to their average radiuses (Figure 10).

Eighteen transversal arches, six barrel arches and four clover-unwrapping (Figure 6) have been achieved in the Saint Athanase church.

### 3.3.2 Circular domes

The domes had also to be documented as raster projection. Due to their spherical shape, a different approach is necessary.

Indeed the double curved surfaces are not developable without any compromise i.e. it is compulsory to chose a flat representation system of the sphere (or projection). The choice of this projection is crucial because some properties (angles, surfaces, distances) can be retained but not together. Angles are retained in conformal projections, surfaces in area equivalent projections and other projections can retain distances (only for particular lines).

Area-equivalent projections are often interesting for restoration purposes because the amount of work and material needed is then easier to evaluate but they conduct to heavy distortions too difficult to manage to have a faithful view of reality.

The orthographic projection has been chosen because it facilitated the insertion of the raster projections in the final documents: sections and plan of the ceiling (Figure 9). Actually it consists in orthophotos of the circular domes.

The treatment is rather similar to the one applied to the cylinders, a previously used program performed the projection and, fortunately, the surface fitting algorithm did not reveal any important deformation.

A dome is projected on five directions, four lateral orthogonal projections and a ground projection. To simplify the process, a transfer raster image whose coordinates  $(i,j)$  are the spherical coordinates  $(\varphi,\lambda)$  is created. It consists in the simplest existing projection and is known as a flat square representation. It acts as a data source for all type of projections (Guerra, 2000).

### 3.4. Other domes

For the documentation of the remaining domes we decided to present them in the same way that the cupolas with a five directions projection.



Figure 7. The dome in the cell T4L2. Left the mesh describing the surface, right the textured photo-model. Below, the orthophoto.

Nevertheless, it is difficult to adapt representation systems to non-analytical surfaces. The simplest way to perform this documentation was to create a 3D model of the dome by convergent photogrammetry and to texture it. This task was perfectly performed in Photomodeler. The exported photo-model was rendered in the five interest directions and the raster projection was then inserted in the sections besides the other domes.

Though simple, this way to proceed is much longer than the treatment of analytical surfaces because of the definition of the real shape of the domes that demands many points to obtain an accurate mesh (Figure 7).

## 4. CONCLUSION

As a result, the diversity and complementarity of the techniques employed has permitted to achieve this challenging survey. The restoration works began during summer 2004 and continue in 2005 with French, Greek and German restorators. The roof of the Saint-Athanase church has been changed in early 2004 contributing to preserve the inside.

The other two surveyed churches are not yet processed.

## REFERENCES

- Guerra, F., Miniutti, D.: The cartographic projections for the representation of double curved surfaces. *International Archives of Photogrammetry and Remote Sensing*, Vol. XXXIII, Part B5, Amsterdam, 2000, pp. 533-538.
- Karras, G. E., Patias, P., Petsa, E., Ketipis, K.: Raster projection and development of curved surfaces. *International Archives of Photogrammetry and Remote Sensing*, Vol. XXXII, Part 5C1B, Göteborg, 1997, pp. 179-185.
- Kraus, K., *Photogrammetrie, Band 2 Verfeinerte Methoden und Anwendungen*, 1996, Dümmler Verlag, Bonn.

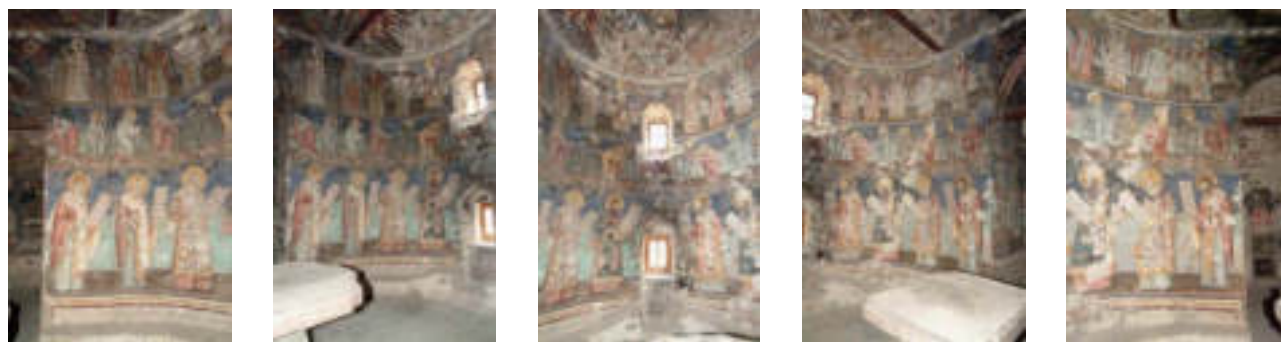

A. Original images



B. The final mosaicked document.

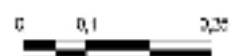

C. Details at scale 1/20 and 1/10

Figure 8. Digital unwrapping of the partially cylindrical apse. ( $R=1.83m$ ,  $\sigma_R=1.1cm$ )



Figure 9. Orthophotos of the circular dome T5L2, left the lateral projections and right the ground projection. ( $R= 1.94m$ ,  $\sigma_R=2.3cm$ )



Figure 10. Longitudinal section L2 (view to the north) through the apse and orthophoto.



Figure 11. A multi-cylinder unwrapped image (four cylinders and two plans are composing the extruded profile).